

STEAM TURBINE BYPASS VALVES

MODEL DSCV-SA

COPEL VULCAN®



Copes-Vulcan has been providing control valves and desuperheaters for the power, process and nuclear industries since 1903. Copes-Vulcan provides a wide range of valves for the control of pressure, temperature and flow-induced noise in all types of power plants. Products include severe service and general service control valves, variable orifice desuperheaters, Raven™ trim and steam-conditioning valves and nuclear control valves, as well as custom designed speciality valves. Copes-Vulcan is recognized worldwide as a leader in valves for severe and critical service applications. Our strength lies in our ability to provide innovative valve solutions for our customers' application needs.



DSCV-SA

DIRECT STEAM CONVERTING VALVE – STEAM ATOMIZATION

The DSCV-SA (Direct Steam Converting Valve – Steam Atomization) is a leading, world class product that embraces the demands of operational excellence, very tight shut off, eliminates thermal shocks, high rangeability, size and installation flexibility combined with low maintenance.

The Copes-Vulcan Pressure Reducing and Desuperheating Valve known as the DSCV-SA, is of angle style construction with the steam inlet through the branch connection and the steam outlet through the in-line connection. The connections can be either flanged or butt welded depending upon the customer preference. The units are manufactured in two parts to allow for greater customer flexibility. The high pressure side of the unit is of cast or forged construction with the lower pressure outlet section being of fabricated construction.

The valve is provided with a bolted bonnet closure for pressure ratings up to and including ANSI 900# and a pressure seal closure for ratings ANSI 1500# up to and including ANSI 4500# rating. The valve can be fitted with single stage HUSH, multi stage HUSH or Copes-Vulcan RAVEN trim technology depending upon the pressure drop and to meet the requirements of specific noise levels. The valve is provided with high pressure balancing, single seat trim construction utilising a tandem trim pilot operated concept ensuring tight and repeatable class V shutoff per ANSI/FCI 70-2.

CAN BE EQUALLY EMPLOYED AS A TURBINE BYPASS VALVE OR STEAM LETDOWN STATION.

- Repeatable class V tight shutoff
- High pressure balanced
- Full plug guiding with anti-rotation
- Steam atomisation of the cooling water
- Low coolant pressure required
- High water capacity for large cooling duties
- High turndown ratio for both steam and water
- Noise attenuating trim options
 - Single stage HUSH
 - Multi stage HUSH
 - RAVEN
- Extremely flexible
 - Flanged or butt weld connections
 - ANSI 150 – 4500, standard, intermediate and split classes
 - Minimum straight line lengths required
- Low maintenance
- 'Quick-Change' trim design no special tools

The DSCV-SA (Direct Steam Converting Valve – Steam Atomization) from Copes-Vulcan is designed for unprecedented operational reliability and eliminates potential risks associated with substandard designs during plant start-up, shutdown and turbine trips. As a result, the DSCV-SA is at the forefront of modern thermodynamic engineering in steam conditioning.

Key to the DSCV-SA's performance are a number of unique technical innovations developed by Copes-Vulcan following extensive consultation with customers in the power generation sector.

THEORY OF OPERATION

Steam atomization has several benefits over mechanically spraying the cooling water via nozzles. Mechanical spray nozzles, even spring loaded types are limited in their turndown as the water atomization and spray pattern degrade as the water flow rate and available pressure differential reduces. As the water demand reduces, the spray water control valve closes and the spray valve trim absorbs the water pressure differential leaving little pressure differential for the spray nozzles. This lack of pressure differential at the spray nozzles does not allow them to atomize the spray water, leading to the water pouring into the steam rather than a fine atomized mist. Mechanical spray nozzles also rely on the surrounding steam velocity to provide adequate mixing. When the steam load reduces so does the steam velocity and the ability of mechanical spray nozzles equally reduce. This effect manifests itself with poor downstream steam temperature control and water 'drop-out'. Water drop-out can be very damaging as cold water will track along the bottom of the inside wall of the downstream pipe while un-cooled superheated steam travels along the top and sides. This produces high thermal shocks which can lead to steam header fracture.

The DSCV-SA employing steam atomization for the cooling water introduction has several major benefits. The atomizing steam pre-heats the cooling water and significantly accelerates the evaporation and desuperheating process. Equally important is to finely atomize the incoming cooling water. Very fine atomization produces extremely small water droplet sizes with a massively increased surface area to promote rapid heat transfer. The atomized, pre-heated water is introduced into the centre of the steam flow with the finely atomizing cooling water being carried by the atomizing steam itself and therefore has no dependency on the main steam velocity. Therefore, for turndown, the DSCV-SA is unrivalled.

TYPICAL PRODUCT APPLICATIONS

Combined Cycle Power

Boiler Main Feedwater Control Valves
Boiler Feed Pump Minimum Flow Recirculation
HP & LP Heater Drain Control Valves



Combined Cycle Power

Drum Level Control
Interstage Attemperators
Steam Pegging Valve



Nuclear Power

Primary and Secondary Circuit Control Valves
Boiler Main Feedwater Control Valves
Turbine Bypass



LNG

Gas Compressor Anti-Surge Valves
Emergency Depressurising Valves
Gas Coolers (Desuperheaters)



Oil and Gas

Steam Letdown Stations
Hot Gas Bypass Valves
Expander Bypass



PRODUCT FEATURES

The DSCV-SA valve has a very tight shut off in the closed position, as a minimum ANSI FCI 70-2 class V. It achieves this tight shut off by utilizing a pilot plug design so that in the closed position, the main plug is unbalanced with the full steam pressure acting on the top of the plug. This load, combined with the actuator thrust, results in very high seat contact loads, which ensures a very tight shut off.

When an open command signal is received, the actuator retracts and the pilot plug is the first to open. This allows P1 steam to flood through the large pilot plug port to the underside of the main plug. The main plug is now high pressure balanced reducing the actuation thrusts required.

High pressure balancing or P1 balancing is a key design feature of the DSCV-SA for reliable smooth operation. Some other designs employ low pressure or P2 balancing; however, these low pressure balancing systems rely on auxiliary balancing seals such as piston rings and close tolerance sealing surfaces to prevent the high pressure steam unbalancing the trim. In operation, if these seals or surfaces wear or become damaged, the trim quickly becomes unbalanced and stem loads dramatically increase and fluctuate which can result in the valve oscillating violently or even unable to open on command.

With the pilot plug open, high pressure inlet steam floods the underside of the main plug and the steam atomizing unit is now operating in preparation to receive the incoming cooling water from the water control valve. The pilot plug shoulder engages with the underside of the tandem cap of the main plug. The main plug then starts to lift and the main seat opens.

As the main plug opens, steam first enters the valve via a heavy duty distribution spacer. The steam passes through the spacer by means of numerous holes

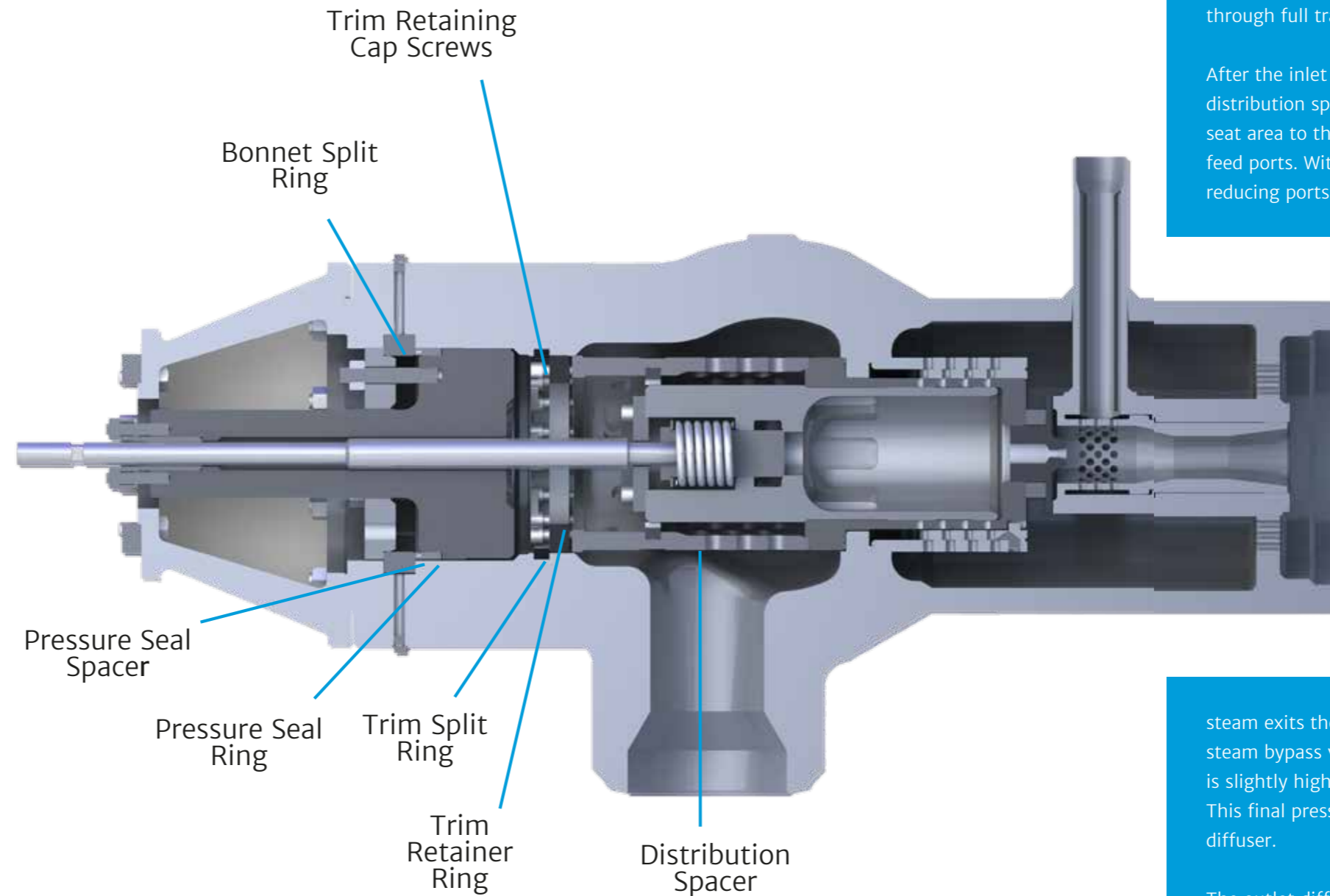

evenly positioned around the circumference. This heavy duty distribution spacer has been specifically designed to negate any upstream pipe work induced flow disturbance being communicated to the main plug. Therefore, long radius bends or isolation valves can be fitted directly to the valve inlet to minimize installation space. The main plug is fully guided by the cage and spacer to ensure complete plug stability through full travel.

After the inlet steam has passed through the distribution spacer it now travels through the main seat area to the underside of the main plug via large feed ports. With the main plug lifted the pressure reducing ports of the cage are now open to allow

the steam to be pressure reduced in a controlled manner. As the main plug opens further more pressure reducing ports are exposed and the steam flow rate increases.

The DSCV-SA steam turbine bypass valve can be supplied with its industry proven active noise attenuation trim styles, Single and Multi-stage HUSH or the multi-labyrinth, multi-disk RAVEN.

The pressure reduced steam exits the cage into the outlet section of the steam bypass valve. The steam pressure in this area is slightly higher than the final downstream pressure. This final pressure drop is taken across the outlet diffuser.

The outlet diffuser has several functions; it aligns the steam that has exited the pressure reducing cage providing a perfect mixing zone for the introduction of the cooling water. It also provides a very secure anchor point for the steam atomizing head. The diffuser forging can also be used as a material transition point to eliminate on-site dissimilar welding, as the bypass valve is an ideal point which piping engineers can utilize to change piping class and material.

PRODUCT SPECIFICATIONS

DESIGN

Standard body-to-bonnet joint, up to ANSI 900#, is bolted and incorporates a fully enclosed spiral wound gasket made from 300 stainless steel with graphite filler. Because the DSCV has a split rated design this provides the customer with a convenient point for pipe transition for size, rating and material. As the DSCV-SA is of two-part construction virtually any configuration can be met to satisfy any client requirements. For pressure ratings above ANSI 900# a pressure seal bonnet closure is employed, which utilizes a graphite-sealing ring.

SIZES

The DSCV-SA is available in an almost infinite range of sizes as each valve is tailored to suit a particular customer's requests and requirements. Additional Noise Attenuation can be performed by utilising a specifically engineered RAVEN multi-labyrinth trim design utilising upon 18 stages of pressure reduction.

PRESSURE RATINGS

The DSCV-SA valve can be fully or split rated design and available in standard, special or intermediate class. Standard classes are available up to and including ANSI 4500#, intermediate and special class designs can be accommodated were required.

MAINTENANCE

The DSCV-SA is not a high maintenance valve. However, the complete trim is a 'Quick-Change' style with no welded in components or large internal threaded parts. The whole trim assembly is held in compression by either a compression ring or the bonnet. By simply removing the compression ring or bonnet the whole trim merely slides out of the top of the valve. Therefore, in-situ maintenance should it be required, is both expeditious and uncomplicated with no need for any specialised tooling or training.

ACTUATION

Steam turbine bypass systems must be able to react and modulate very quickly under emergency conditions such as a turbine trip. Stroking speeds of less than one second may be required. The DSCV-SA can be supplied with either pneumatic or hydraulic actuation to meet this critical requirement.



MATERIALS OF CONSTRUCTION



The valve can be manufactured from any material to meet specific design requirements. Standard materials are as shown below:

BODY & BONNET

Carbon Steel to ASTM A216 WCB / ASTM A105
Alloy Steel to ASTM A217 WC6 / ASTM A182 F11
Alloy Steel to ASTM A217 WC9 / ASTM A182 F22
Alloy Steel to ASTM A217 C12A / ASTM A182 F91

BONNET STUDS AND NUTS

The standard body-to-bonnet studs and nut materials for bolted bonnets are:

For applications up through 454°C (850°F):

Studs: ASTM A193 Grade B7

Nuts: ASTM A194 Grade 2H

For applications over 454°C (850°F) to 565°C (1050°F) in low alloy steel:

Studs: ASTM A193 Grade B16

Nuts: ASTM A194 Grade 4

STEM MATERIALS

Stems are made from 17/4 ph grade
ASTM A564 GR630.

OTHER OPTIONS

Double Packed Bonnet

When packing leakage is to be minimised, a double packed bonnet may be used. The lower packing set provides primary sealing between the internal Valve fluid and the leak off tube while the back up prevents leakage to the atmosphere.

Lubricator

Stem packing lubricators can be provided on the bonnet assembly but are not considered necessary with graphoil packing.

PACKING MATERIAL

Standard Packing is Compressed graphite die formed rings with braided graphite end rings to prevent extrusion of the packing. The packing is used in a bolted compression type gland arrangement

TRIM MATERIAL

This will vary depending on the application for which the valve is being used, but the standard materials

Plunger – ASTM A217 WC6

Cage Assembly – ASTM A217 WC6

Distribution Spacer – ASTM A217 WC6

Pilot Plug – BS970 420 S37

Atomiser Nozzle – BS970 316 S31

The trim components are given additional heat treatment to give increased hardness at elevated temperatures. This additional treatment is also used to ensure superior performance in high-pressure drop applications.

LIVE LOADED PACKING

This packing arrangement provides a more constant force on the packing, which minimises packing leakage over time. This feature is often used when the valve is to be located in an area where it is difficult to perform maintenance on the valves.



DSCV-SA STEAM TURBINE BYPASS VALVES

- | SPEED
- | EXCELLENCE
- | PARTNERSHIP

 COPES VULCAN®

Celeros Flow Technology
Road Two
Industrial Estate
Winsford, Cheshire
CW7 3QL

P: +44 1606 552041
F: +44 1606 558275
E: copeinquires@celerosft.com

*Celeros Flow Technology reserves the right to incorporate our latest design and material changes without notice or obligation. Design features, materials of construction, and dimensional data, as described in this bulletin, are provided for your information only and should not be relied upon unless confirmed in writing. Please contact your local sales representative for product availability in your region. For more information, visit www.celerosft.com.
CV_Bypass-Valves_427_PB_A4_ Version 01/2021 Issued 01/2021
COPYRIGHT © 2021 CELEROS, Inc.*

www.celerosft.com