

CUP-BB2 / CUP-BB2T

HEAVY DUTY, RADIALLY SPLIT, SINGLE &
TWO STAGE PUMPS

CLYDEUNION®
PUMP

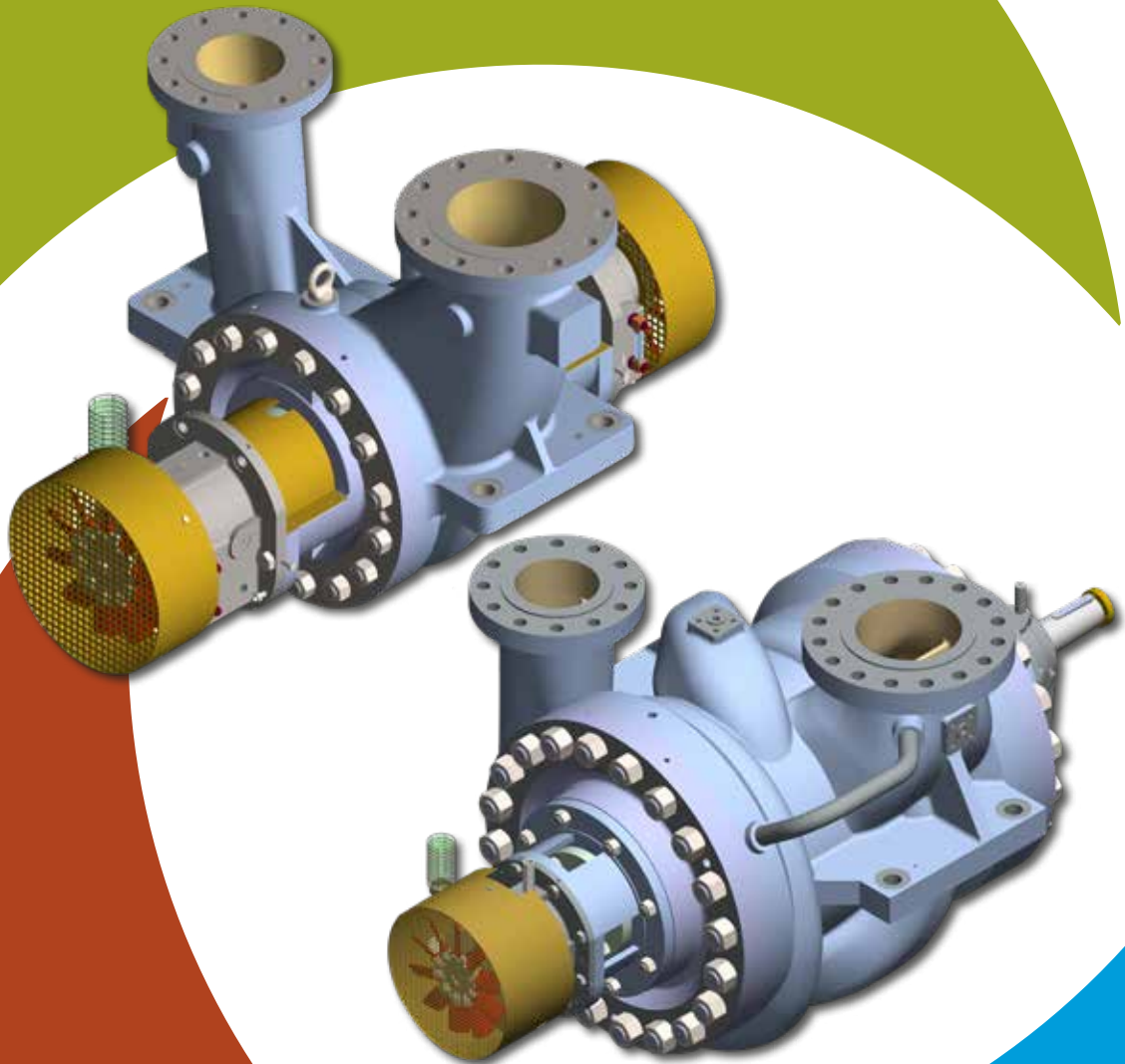

CLYDEUNION PUMPS – AN INTRODUCTION

ClydeUnion Pumps is the culmination of a long and eventful 140-year engineering legacy. In fact, most nuclear power plants currently in operation around the world employ our reactor feed pumps. We play an instrumental role in securing the vital energy and water resources that a sustainable society will rely on in the future.

Not only servicing the Nuclear market we are also a valued flow control engineering partner to the oil/gas industry – supporting upstream, downstream, transportation and offshore exploration activities. Other key areas we address include seawater desalination, waste water treatment, mining and steel production.

Combining a wealth of pump and system design knowledge, latest design, analytical and pump testing equipment, we are confident we can boost efficiency and ensure prolonged operation of our products.

At Celeros FT, you will find a commitment to quality throughout the company. Our Quality Management System is fully approved to ISO 9001:2008 and independently verified to comply with the latest quality standards. Our ClydeUnion Pumps brand has a worldwide reputation for providing optimised reliability, with our API 610 centrifugal pumps and pumping packages, in the most severe duty applications.

REFINERIES

Today's complex refinery processes demand specialised pumping solutions. Extremes of temperature, high pressure and the ability to handle volatile fluids, calls for highly engineered pumps that can perform reliably in such arduous conditions. With many years of worldwide experience in supplying ClydeUnion process pumps to the refinery industry we are committed to providing our customers with solutions for the most complex of pumping requirements.

PETROCHEMICALS

The process and transferring of petrochemicals demands a high level of pumping reliability, and the ClydeUnion Pumps brand has a reputation for supplying reliable pumps which can be found working throughout the world in the most aggressive applications.

OIL & GAS PRODUCTION

Our pumps can be found operating wherever

there are oilfields, both onshore and offshore. High efficiency and reliability are major benefits of ClydeUnion Pumps equipment – both of which are vital considerations in the oil and gas industry. Pumps have been supplied to satisfy a wide range of pumping services including high pressure seawater injection, crude oil transfer and pumps for handling all types of industry related fluids.

POWER

ClydeUnion boiler feed pumps and auxiliary services have been supplied for a wide range of power generation plants over many years. The experience gained in this field enables us to offer our customers engineered products, tailored to their specific requirements.

TYPICAL APPLICATIONS

- Refinery processes
- Booster
- Boiler feed booster
- Upstream processes
- Gas processing
- Petrochemical
- Nuclear / conventional power
- Bio fuels
- Jet fuel



PUMP OVERVIEW

PUMP TYPES

- CUP-BB2-D Heavy duty, radially split, single stage double suction pump
- CUP-BB2T-S Heavy duty, radially split, two stage single suction pump
- CUP-BB2T-D Heavy duty, radially split, two stage double suction pump

CUP-BB2 type pumps are horizontal, centerline or foot mounted, radially split, one and two stage, between bearing pumps, designed and manufactured to the latest edition of API 610 and available with top-top or side-side suction and discharge connections.

The CUP-BB2 pumps are employed for many oil and gas, power, extreme refinery process and general industrial applications. Stringent API noise and vibration limits are met due to a rigid pump body with 180 or 360 degree bearing support and heavy centre-line or foot mounting.

Reliable operation at elevated temperatures is ensured due to a number of cooling methodologies complementing inherently cool running bearing modules. ClydeUnion Pumps legacy brands including HOL, HOS, KSMK, DB21, DB22 and HOB provide the industry with a very comprehensive hydraulic coverage.

PROVEN PRODUCT INTEGRITY

The ClydeUnion CUP-BB2 and BB2T encompass proven design experience. From the David Brown DB21, Guinard KSMK, Union HOL and Weir HOB a strong history of sound and proven engineering are all designed to exceed the rigorous requirements of API 610. The CUP-BB2 and CUP-BB2T pumps are among the most robust in the industry with superior design features providing long and trouble free operation.

INDUSTRY LEADING RELIABILITY

The heavy duty construction of the CUP-BB2 pump ensures that our units can operate on even the most demanding applications with exceptional reliability and a very high mean time between failures (MTBF). Celeros FT can also provide a complete service solution to ensure units are continually in 'as new' condition.

PUMPSETS & PACKAGES

Celeros FT has extensive experience in providing complex pumpsets including electric motors, gearboxes, lube oil systems, steam turbines, diesel engines, control panels and instrumentation.

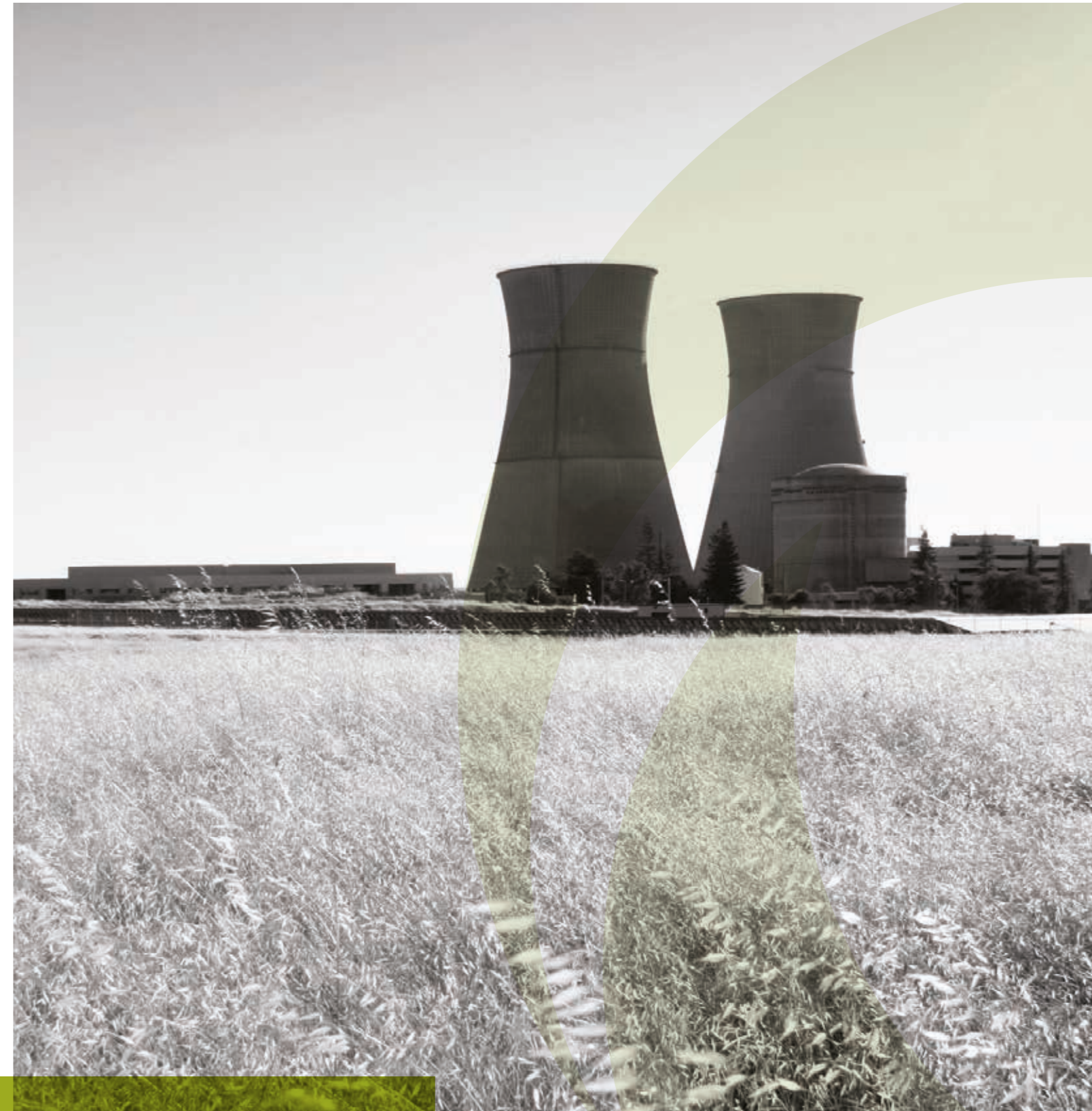

CUP-BB2 / BB2T - FEATURES

- 1 BEARING ASSEMBLY**
 - 180° and 360° mount provides class leading vibration levels for every service
 - High capacity fan as standard
 - Pure and purge mist options
 - High temperature options up to 800°F (427 °C)
- 2 SEAL CHAMBER**
 - API 682 compliant
 - Design accommodation for dual seals
 - Easy access for maintenance and locking collar arrangement as standard
- 3 FLANGE FINISHES & RATING**
 - Standard options available in 300 and 600 flange rating
 - Higher pressure options available
 - Raised face and ring type joint options available
- 4 INTEGRALLY FLANGED VENT / DRAIN CONNECTIONS**
 - Eliminates weld connection
 - Eliminates need for bracing
- 5 CASE WEAR RINGS & BUSHES**
 - Positive location
 - Tack welded or pinned for anti-rotation
 - Renewable case rings
 - Integral wear rings as standard
- 6 IMPELLER(S)**
 - Individually secured, precision cast
 - NPSH optimized using CFD
 - Hydraulically designed to balance axial loads to increase bearing life.
 - Impeller balance to G1.0 standard
- 7 RADIALLY SPLIT CASING**
 - Centerline or foot mounted
 - Allows densities below 0.4 SG
 - Allows temperatures up to 427°C (800°F)
- 8 ROBUST ROTOR DESIGN**
 - Stepped shaft for ease of assembly
 - Optimised rotor dynamics and power transmission capability
- 9 API SHAFT TAPER**
 - For easy coupling removal
- 10 MATERIAL OPTIONS**
 - All API 610 material options
 - Other material options available
 - NACE compatible
 - Non metallic wear parts
- 11 API 610 DESIGN**
 - Compliant with latest API 610 specification
 - Designed to exceed stringent API criteria

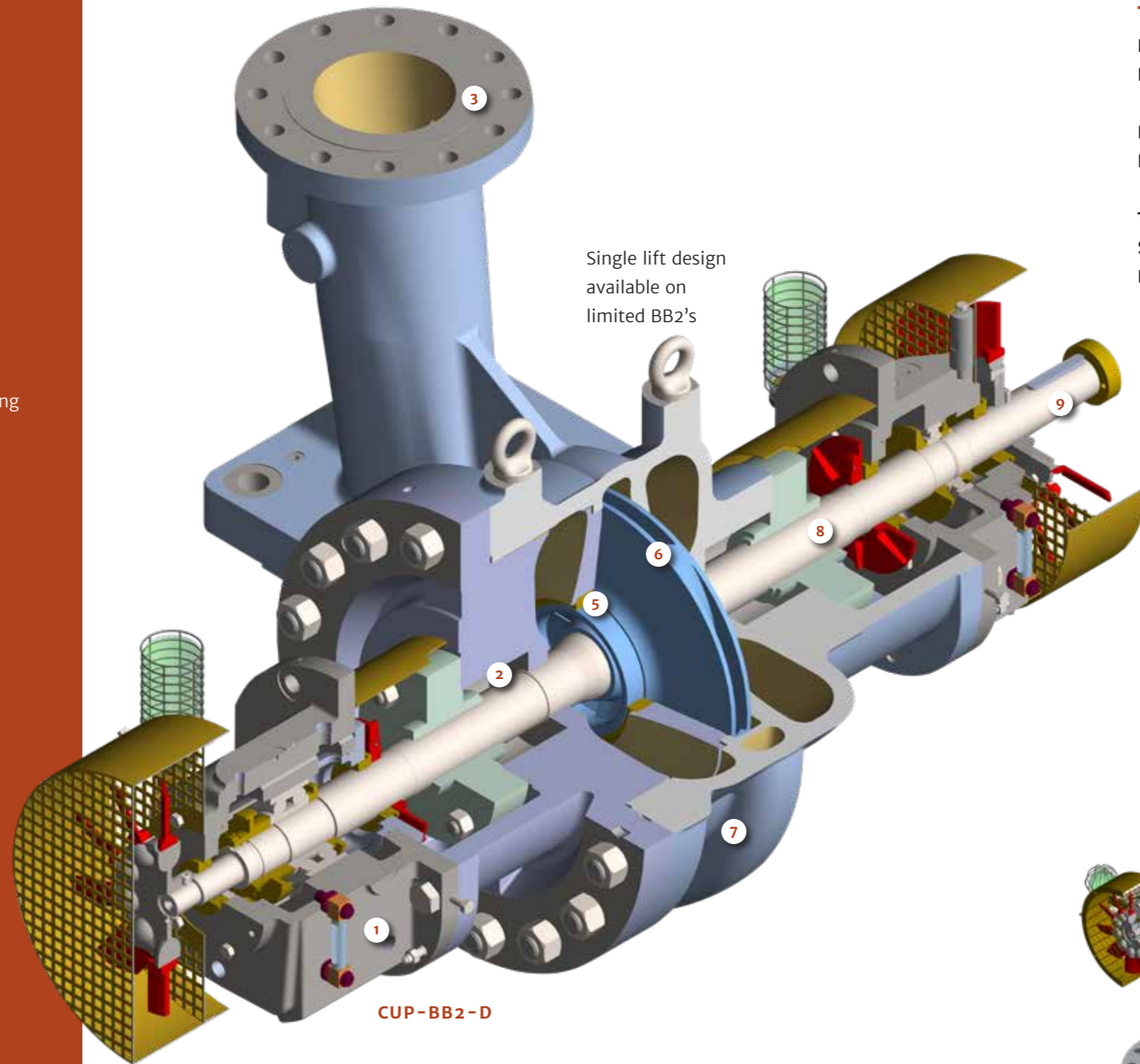

TECHNICAL DATA

BB2 Capacity: up to 3,500 m³/hr / 15,410 USgpm

BB2 Delivery head: up to 450m / 1,475 ft

BB2T Capacity: up to 1,600 m³/hr / 7,045 USgpm

BB2T Delivery head: up to 700 m / 2,300 ft

Temperature: up to 427 °C / 800 °F

Speeds: up to 3,600 rpm

Flange drilling: ANSI or BS

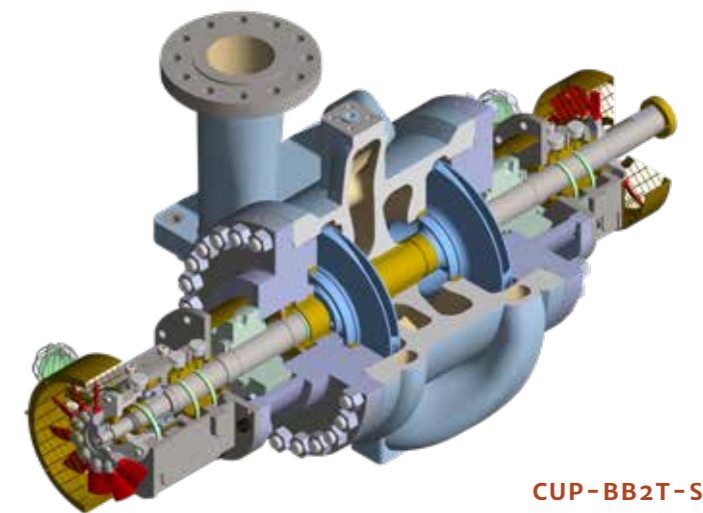

VARIETY OF NOZZLE CONFIGURATIONS

- Top-top and side-side same side standard
- Opposite side-side nozzles available
- Both 1 and 2 stage BB2 options

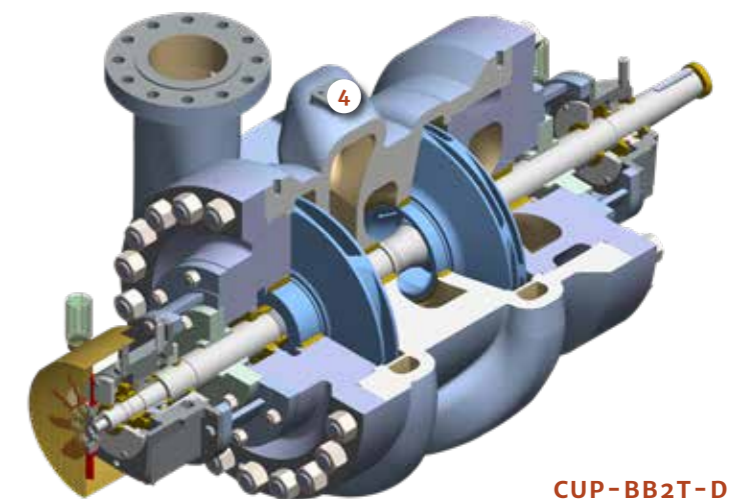

OPTIONAL ARRANGEMENTS & FEATURES

STANDARD BALL/BALL BEARING ASSEMBLY

- Designed for minimum 25,000 hour L10 bearing system life
- Surpasses the API limits for oil sump temperature and bearing temperature rise
- Angular contact bearings with machined brass cages
- Rapid bearing stabilisation achieves operating temperatures well within API limits
- INPRO™ bearing isolators throughout, give reduced contamination for improved bearing life
- Proven reliability in a wide range of applications, speeds and environments

OPTIONAL SLEEVE/BALL BEARING ASSEMBLY

- Energy density applications beyond ball/ball bearing limits
- Available for applications up to and beyond API limits
- Hydrodynamic radial bearing and optimally sized angular contact thrust bearings designed for 100,000 hour L10 life, under stable operating conditions

OPTIONAL SLEEVE/TILTING PAD BEARING ASSEMBLY

- High power pumps up to 6.75 MW
- Designed for infinite life

CP SEAL SYSTEM

- All CUP-BB2 pumps are designed for use with our patented CP System (Plan 53C)
- CP System technology offers a proven history in improving seal life, particularly under varying suction pressures
- The unique CP System design provides an excellent mechanical sealing environment in the most demanding process conditions

CARTRIDGE BEARING DESIGN

- “Maintenance Friendly” design alternative, requiring a concession when used on an API pump
- Allows bearing removal and refit within an hour
- Cartridge can be pre-assembled in clean environment prior to transportation to the field
- Contains all the advanced features of the standard design

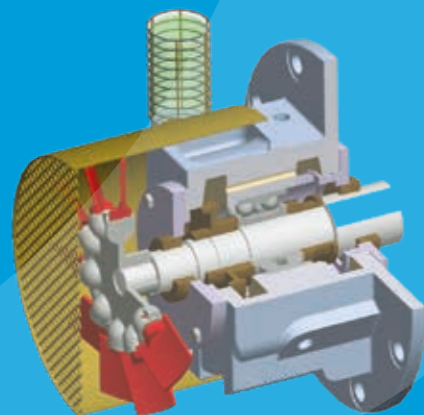

Standard ball/ball bearing assembly

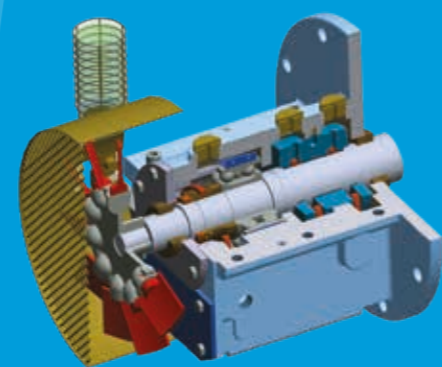

Optional sleeve/ball bearing assembly

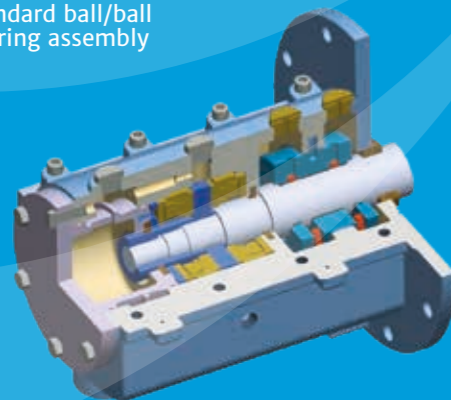

Optional sleeve/tilting pad bearing assembly



STANDARD HYDRAULIC RANGE - COVERAGE CHARTS

50HZ RANGE COVERAGE CHART

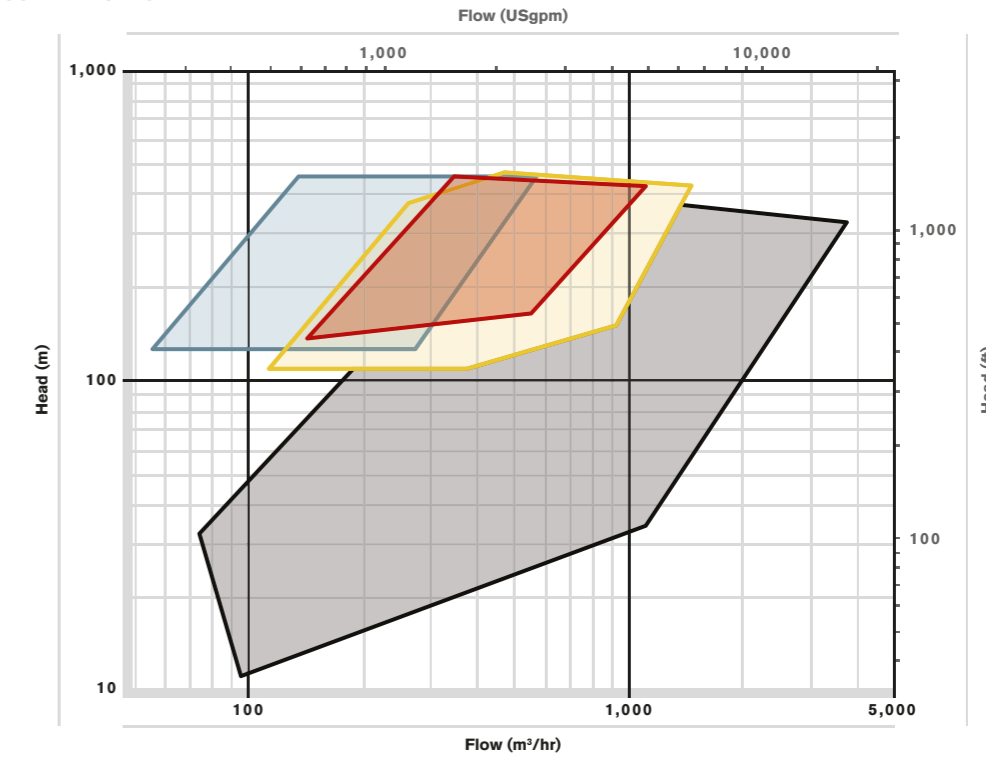

60HZ RANGE COVERAGE CHART

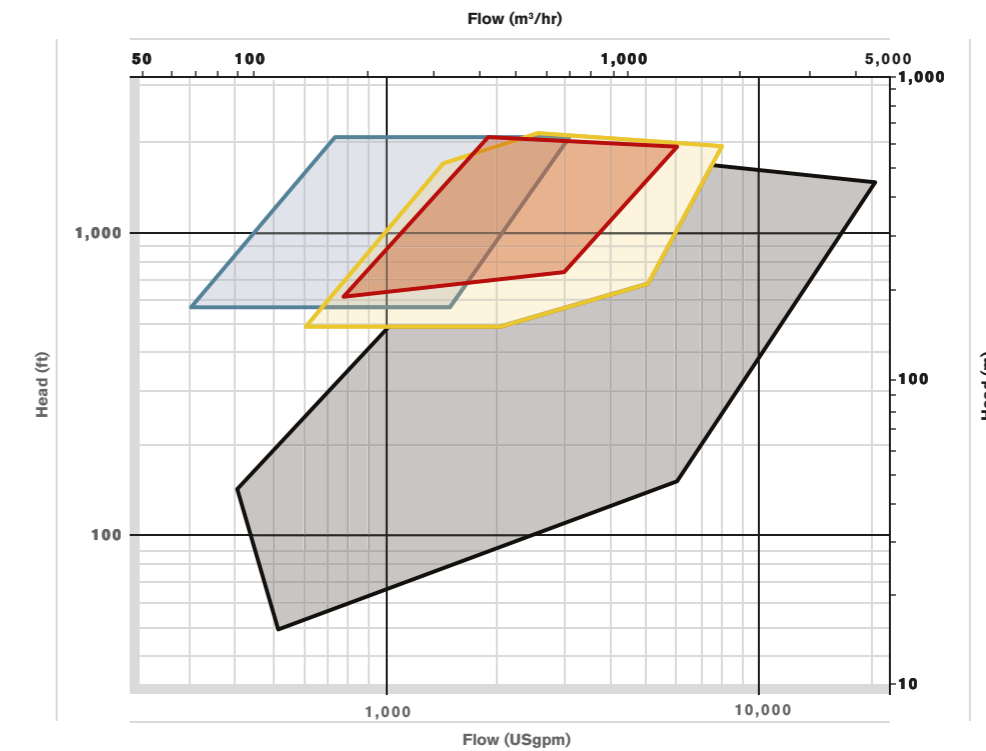

These charts cover the CUP-BB2 standard pump range. Other engineering designs exist for extreme applications

- CUP-BB2 2 pole
- CUP-BB2 4 pole
- CUP-BB2T 2 pole
- CUP-BB2T 4 pole

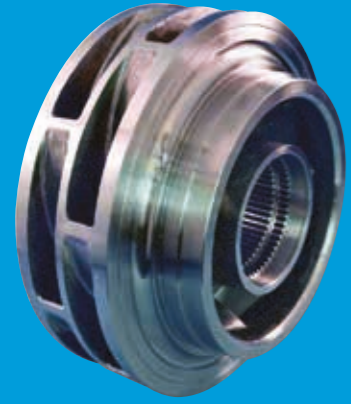

GLOBAL AFTERMARKET CAPABILITY BEST IN SERVICE & RESPONSE

Our customer focused aftermarket organisation is positioned to provide comprehensive care for our varied and diverse product lines. Heritage and obsolete products benefit from the same level of attention and expertise ensuring that reliability and availability is maximised irrespective of a pump's length of service.

GENUINE HIGH QUALITY

Original or upgraded specification spare parts, coupled with full engineering design capability, enables longevity of reliable operation. Highly skilled and experienced service engineers ensure accuracy in build and optimised performance. The worldwide presence of Celeros FT offers local service facilities in over 40 countries.

SERVICE SOLUTIONS

Celeros FT is committed to supporting our installed base wherever it may be. Depending on your location we will provide either direct service support or support via our local authorised service partners. Whichever option is provided, you can be assured of the best attention from fully qualified and experienced engineers.

UPGRADES & RE-RATES

- Service & overhaul
- Installation & commissioning
- Technical support
- Inventory management
- 3rd party equipment



Parts & maintenance:

Any brand, any material, anytime. Heritage products, upgrades & improvements



CUP-BB2 / CUP-BB2T

HEAVY DUTY, RADIALY SPLIT,
SINGLE & TWO STAGE PUMPS

| SPEED
| EXCELLENCE
| PARTNERSHIP

CLYDEUNION®
PUMP

EUROPE

Annecey	P: +(33) 45 005 5600	E: cu.annecy@celerosft.com
Glasgow	P: +(44) 141 637 7141	E: cu.glasgow@celerosft.com

AMERICAS

Baton Rouge, LA	P: +(1) 225 775 2660	E: cu.batonrouge@celerosft.com
Battle Creek, MI	P: +(1) 269 966 4600	E: cu.battlecreek@celerosft.com
Burlington, ON	P: +(1) 905 315 3800	E: cu.burlington@celerosft.com
Calgary, AB	P: +(1) 403 236 8725	E: cu.calgary@celerosft.com
Los Angeles, CA	P: +(1) 562 622 2380	E: cu.downey@celerosft.com
Houston, TX	P: +(1) 281 372 5040	E: cu.houston@celerosft.com

ASIA

Beijing	P: +(86) 10 5926 7000	E: cu.beijing@celerosft.com
New Delhi	P: +(91) 120 4640 400	E: cu.newdelhi@celerosft.com
Shanghai	P: +(86) 21 2208 5888	E: cu.shanghai@celerosft.com
Singapore	P: +(65) 62 76 7117	E: cu.singapore@celerosft.com

Middle East/Africa

Abu Dhabi	P: +(971) 2 408 1900	E: cu.uae@celerosft.com
Dubai	P: +971 4 5289555	E: cu.uae@celerosft.com

Celeros Flow Technology reserves the right to incorporate our latest design and material changes without notice or obligation.

Design features, materials of construction, and dimensional data, as described in this bulletin, are provided for your information only and should not be relied upon unless confirmed in writing. Please contact your local sales representative for product availability in your region. For more information, visit www.celerosft.com.

CUP_BB2-BB2T_222_PB_A4_Version 01/2021 Issued 05/2021

COPYRIGHT © 2021 CELEROS, Inc.